

## Self-Cleaning Filters

# DELTA-STRAIN 480-S/L

## For hydrous, viscous and super-viscous media

The wedge-wire filter from DELTAFILTER is a logic, cost-efficient and environmental-protecting way of filtration.

- No cartridge filters waste
- Self-cleaning without interruption of process
- In- and outlet at the same height
- Robust and user-friendly filter housing in two parts with DELTA-spindle-quick-action-cover-closure for one hand operation – no tool is required to open and close the housing
- Low operating costs due to a long service life
- No special spare part stockholding is necessary
- Simple and time-saving maintenance – no dismantling of pipelines
- Filter rates nominal 25 µm – 8000 µm
- Manufacturing acc. to PED 2014/68/EU
- Motor in efficiency class IE3 (High Efficiency)

### OPTIONS

⊕-protection ATEX-conformable acc. to directive 2014/34/EU, perforated elements for gel-like particles, fibres, algae etc., filter elements in hardened design for lifetime improvement, spring loaded scraper blade, self-re-stressed gland unit, special voltage, special seals, automatic drain-system, sluices, heating jacket, differential pressure indicator, wall-holder etc.



DELTA-STRAIN 480-S/L,  
1.4571, 10 bar

We manufacture self-cleaning filters in special construction and alternative material!

## PRODUCT DESCRIPTION

The filter housing, constructed in two parts, has a filter sump with DELTA-spindle-quick-action-cover-closure for one hand operation demountable downwards. The filter system of DELTAFILTER Filtrationssysteme GmbH is extremely robust and designed for extreme applications. If required, the filter element can be dismantled completely without special tools. Special seals are not needed for the filter element. The dirt is removed of the filter element by a flexible scraper-blade of stainless steel and sinks downwards in the mud reservoir of the sump. The dirt can be discharged by a manual valve or optional by an automatic cut off device, which can be controlled by the time or by the differential pressure. Liquid losses are limited. Sluices can be delivered optionally for the concentration of the dirt.

## TECHNICAL DATA

Design and calculations:	PED 2014/68/EU, AD2000
Material of housing:	1.4571 (316Ti) <sup>1,2</sup>
Material of filter element:	1.4435 (316L), 1.4404 (316L), 1.4571 (316Ti)
Material of other internals:	1.4571 (316Ti), 1.4310 (301)
Max. allowable pressure:	10 bar <sup>1</sup>
Max. allowable temperature:	80°C <sup>1</sup>
Housing seal:	O-ring FPM <sup>1</sup>
Filter rates nominal:	25 µm – 8000 µm <sup>3</sup>
Weight (empty):	ca. 48 kg
Drive:	gear-motor
Motor data:	400 V, 50 Hz, 180 W <sup>1</sup>
Motor protection:	IP65 <sup>1</sup>
Flow capacity:	36 m <sup>3</sup> /h (50 – 100 µm) 45 m <sup>3</sup> /h (≥150 µm)
(in relation to clean water)	

## CONNECTIONS

S1 Inlet	BSP 3" inner thread <sup>4</sup>
S2 Outlet	BSP 3" inner thread <sup>4</sup>
S3 Discharge	BSP 1" outer thread <sup>4</sup>
S4 Differential pressure (+)	BSP 1/4" inner thread
S5 Differential pressure (-)	BSP 1/4" inner thread

Illustration, weights and measures are only indices.

## DELTA-STRAIN 480-S/L

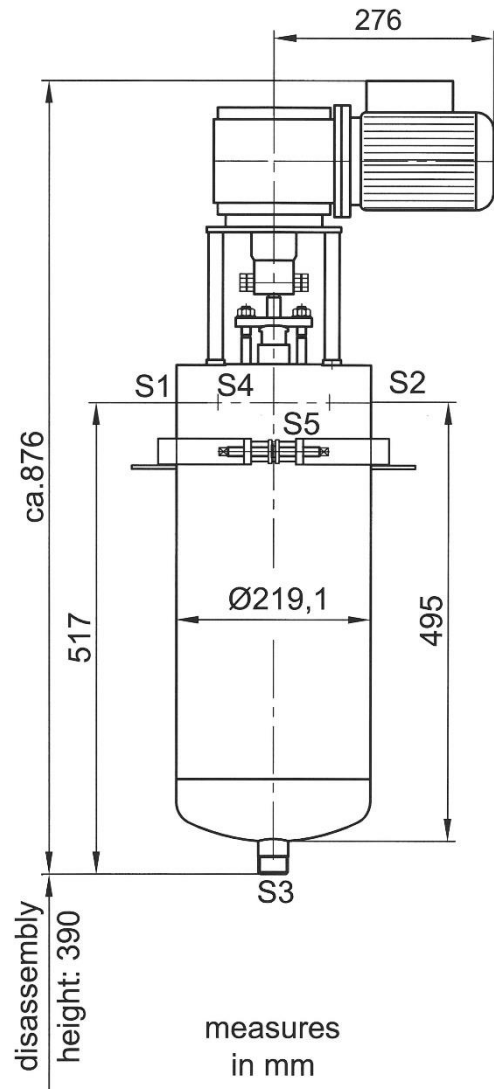

- <sup>1</sup> Optional other materials, pressures, temperatures, voltages, protection ratings etc.
- <sup>2</sup> Surface pickled and passivated
- <sup>3</sup> Optional perforated elements (gel-like particles, fibres, algae etc.)
- <sup>4</sup> Optional with (ANSI-) flanges or welding male part according to German DIN 11851

Our self-cleaning filters model DELTA-STRAIN are available for flow capacities up to 250 m<sup>3</sup>/h as standard versions – higher flow capacities on request.

We will prepare a detailed quotation for you. Test filters are available.

21st March 2024 - Technical changes reserved.



Certified acc. to  
**ISO 9001:2015**

**Phone** +49 / 62 32 / 31 51 31  
**Fax** +49 / 62 32 / 31 51 35

**Email** info@deltafilter.com  
**Web** www.deltafilter.com